

12. LIMITED WARRANTY

Manufacturer warrants this product to the original purchaser for a period of one (1) year from date of purchase to be free from defects in material and workmanship, but not against damages by misuse, negligence, accident, faulty installations and instructions. Manufacturer will repair or replace (at factory's option), free of charge, any component of the equipment thus found to be defective, on return of the component, "PREPAID" to the factory during the warranty period. In no event shall any liability or obligation of the Manufacturer arising from this warranty exceed the purchase price of the equipment. This warranty is only valid if the defective product is returned as a complete assembly without physical damage. The Manufacturer's liability, as stated herein, cannot be altered or enlarged except by a written statement signed by an officer of the company. In no event shall the Manufacturer be liable for consequential or incidental damages. A return authorization is required from Techcon Systems prior to shipping a defective unit to the factory.

Manufacturer reserves the right to make engineering product modifications without notice.

All returns must be issued with a Returns Authorization number, prior to return. Send warranty returns to:

Americas and Asia

OK International
12151 Monarch Street
Garden Grove, Ca 92841

Europe

OK International
Eagle Close
Chandler's Ford Ind Est
Eastleigh
Hampshire
SO53 4NF
United Kingdom

www.techconsystems.com

Teflon is a registered trademark of E.I. DuPont.

Techcon Systems TS934/TS941 TS934A/TS941A High Pressure Spool Valve

User Guide



CONTENTS

	Page number
1. Specifications.....	3
2. Unpacking and Inspection.....	4
3. Description.....	4
4. Theory of Operation.....	4
5. Setup Instructions.....	5
6. Typical System Set-Up.....	5
7. Maintenance and Cleaning.....	6
8. Spare Parts.....	7-8
9. Repair Kits and Seals.....	9
10. Accessories.....	10
11. Troubleshooting.....	11
12. Warranty.....	12

11. TROUBLESHOOTING

PROBLEM	POSSIBLE CAUSE	CORRECTION
No fluid flow	Fluid pressure too low	Increase fluid pressure
	Operating pressure too low	Increase air pressure to 70 psi (4.8bar)
	Dispense tip clogged or damaged	Replace tip
	Fluid cured in valve chamber	Clean valve thoroughly
Inconsistent fluid flow	Fluid pressure fluctuating	Make sure fluid pressure is constant
	Valve operating pressure is too low	Increased valve pressure to 70 psi (4.8bar)
	Valve open time is not consistent	Check to make sure the valve controller is providing a consistent output
	Air trapped in fluid housing	Purge valve
Fluid drools after the valve closes, eventually stopping	Air trapped in fluid housing	Purge valve
Steady drip	Lower seal damaged or worn	Replace lower seal
	Spool damaged	Replace spool
	Inlet air fitting is too long, pushing the spool opened	Replace air fitting
	Valve re-assembled incorrectly	Re-assemble valve, follow re-assembly instructions

10. STANDARD ACCESSORIES

PART NUMBER	DESCRIPTION
TSD700-1	Oiler Cup
TSD931-15	¼" NPT X Female Luer Lock Fitting
TSD918-3	Elbow, ¼-18 NPT X ¼-18 NPT
TSD931-7	Tip Adaptor ¼" NPT
TSD912-15	Reducer, ⅜" NPT X ¼" NPT
TS60C-CON	Cleaning Gel, 6oz (177ml)

10.1 OPTIONAL ACCESSORIES

PART NUMBER	DESCRIPTION
918-006-000	Tip adapter, Metal (Nickel Plated Brass)
934-003-000	Adjustable Suck Back Cap

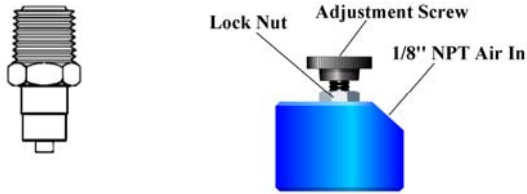

10.2 FITTINGS AND TUBINGS

PART NUMBER	DESCRIPTION
TSD1002-38	¼" NPT to ¼" O.D. Tube
TSD1566-5	¼" NPT to ⅜" O.D. Tube
TSD1099-22	⅜" O.D. X ¼" I.D. Tube, Black, Polyethylene
TSD1099-23	⅜" O.D. X ¼" I.D. Tube, Clear, Polyethylene
TSD1099-24	¼" O.D. X ⅛" I.D. Tube, Clear, Polyethylene
TSD1099-25	¼" O.D. X ⅛" I.D. Tube, Black, Polyethylene
TSD1099-45	6mm O.D. X 4mm I.D, Clear, Polyethylene
TSD1099-46	6mm O.D. X 4mm I.D, Black, Polyethylene

10.3 BRACKETS

PART NUMBER	DESCRIPTION
918-033-000	Productions Master Stand (Base & Support)
918-000-012	Rod Clamp Assembly
918-000-013	TS934/TS941 Series Spool Valve Bracket
918-000-009	6" Non-Threaded Mounting Rod

1. SPECIFICATIONS

	TS934/TS941	TS934A/TS941A
Size	4.7" length X 1.5" diameter (119.4mm X 38.1mm)	4.7" length X 1.5" diameter (119.4mm X 38.1mm)
Weight	TS934 = 1.15lb (522g) TS941 = 1.6lb (728g)	TS934A = 1.16lb (526g) TS941A = 1.61lb (731g)
Fluid Inlet Port	⅜" NPT female	¼" NPT female
Fluid Outlet Port	¼" NPT female	¼" NPT female
Air Inlet Port	¼" NPT female	¼" NPT female
Auxiliary Air Inlet Port	⅛" NPT	⅛" NPT
Minimum Air Pressure	70 psi (4.8bar)	70 psi (4.8bar)
Maximum Fluid Pressure	2,500 psi (172.4bar)	2,500 psi (172.4bar)
Operating Frequency	Exceeds 400 cycles/min.	Exceeds 400 cycles/min.
Wetted Parts	TS941 Fluid housing = Type 303 SS TS934 Fluid Housing = Aluminum Hard Chrome plated Stainless Steel, UHMWPE Seal with EPR O-Ring	TS941A Fluid housing = Type 303 SS TS934A Fluid Housing = Aluminum Hard Chrome plated Stainless Steel, UHMWPE Seal with EPR O-Ring

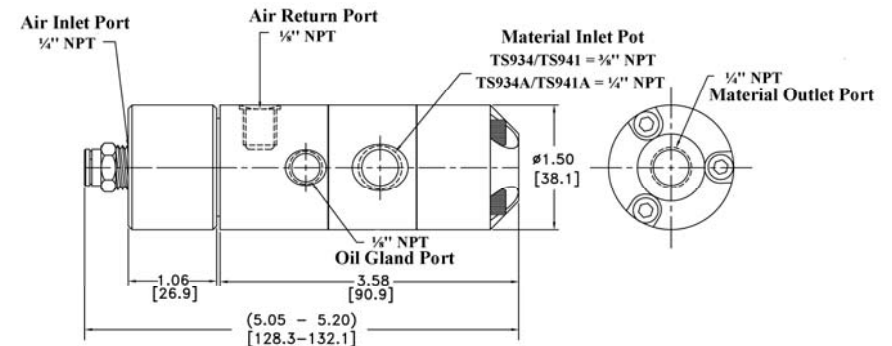

Dimensions are in inches [mm]

Figure 1.0

2. UNPACKING AND INSPECTION

Carefully unpack the valve and examine the items contained in the carton.

These will include:

- Valve assembly
- User guide
- Fitting and Valve Air Hose

Inspect the unit for any damaged which may have occurred in transit. If such damage has occurred, notify the carrier at once. Claim for damage must be made by the consignee to the carrier, and should be reported to the manufacturer.

3. DESCRIPTION

The TS934/TS941 Series Spool Valve is based on a balanced spool design for a fast “ON/OFF” dispensing action. The hardened spool slides in reinforced UHMWPE seals and it suitable for use with fluids having a viscosity of 100 to over 3,000,000 cps, at a pressure up to 2,500 psi (172.4bar). An internal spring return makes the valve fully adaptable for use with Techcon Systems time/pressure controllers.

4. THEORY OF OPERATION

The TS934/TS941 Series Spool Valve is normally closed. When air pressure is applied at air inlet port (1), the spool assembly (2) moves forward to the open position, allowing the fluid to flow from the fluid inlet port (3) to the fluid outlet port (4). Relieving the input air pressure allows the return spring (5) to pull the spool assembly back in the close position, stopping the fluid flow. During the closing position, the spool movement creates a “suck-back” anti-drip feature.

An Oil chamber (6) is provided, above the upper seal, to create an additional liquid seal that will prevent moisture from being carried on the spool. The auxiliary air inlet port (7) is provided so that the valve may be connected for air closing with or without the spring.

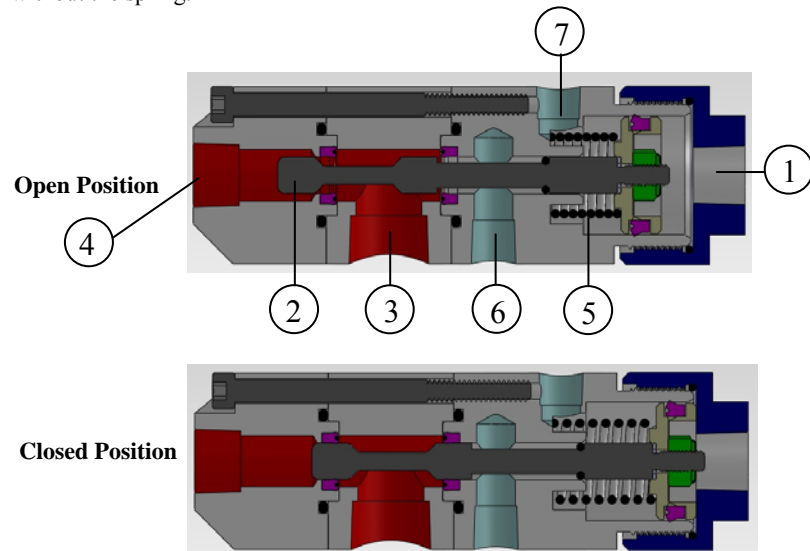
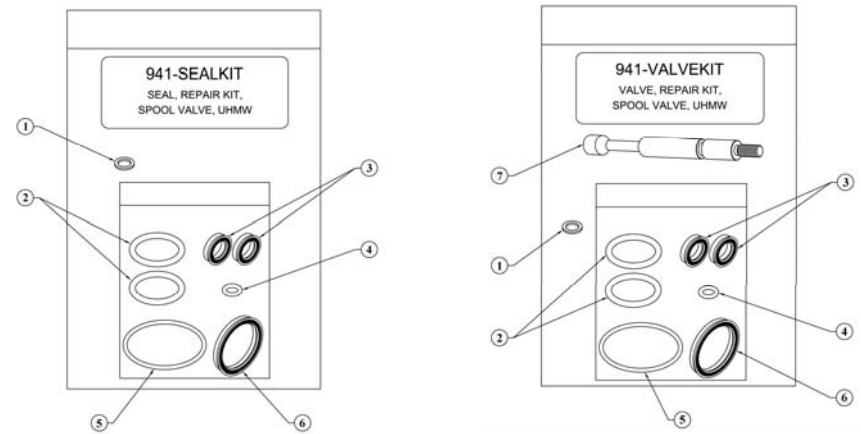

Figure 2.0

9. REPAIR KITS



ITEM	PART NUMBER	DESCRIPTION	QTY
1	TSD1145-1	Fiber Washer	1
2	TSD1400-115C	Chamber O-Ring, EPR	2
3	TSD400-69	U-Cup Seal	2
4	TSD1400-008B	Spool Shaft O-Ring, Viton	1
5	TSD1400-025A	Cap O-Ring, Buna	1
6	TSD1399-2	Piston U-Cup Seal	1
7	934-000-005	Spool Shaft	1

*These kits fit all variations of Techcon Systems High Pressure Spool Valves

9.1 Alternative Seals

Techcon Systems offers alternative seal materials for different applications. The standard seals installed in the valve are made of UHMWPE with an EPR o-ring. Part number = TSD400-69

The following alternative seals are available:

PART NUMBER	DESCRIPTION
TSD400-56	Teflon® seal with EPR expander O-ring
TSD400-58	Teflon® seal with Viton expander O-ring
TSD400-49	Teflon® seal with stainless steel expander spring

SPARE PARTS, CONT.

Valve Front Section

Recommended lubricant:

“Parker -O-Lube”, or equivalent.

All O-Rings & seals must be lubricated with the exception of TSD400-69, which must remain dry.

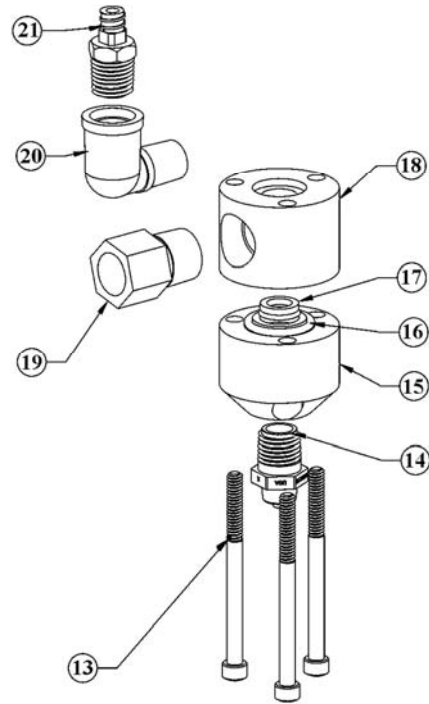

ITEM	PART NUMBER	DESCRIPTION	QTY
13	TSD1103-323	Valve Assembly Screw	3/4
14	TSD931-7	Tip Adaptor 1/4" NPT	1
15*	934-000-003	Material Outlet Block (Al) For TS934	1
15*	934A-000-003	Material Outlet Block (Al) For TS934A	1
15*	941-000-002	Material Outlet Block (SS) For TS941	1
15*	941A-000-002	Material Outlet Block (SS) For TS941A	1
16	TSD1400-115C	Chamber O-Ring, EPR	2
17	TSD400-69	U-Cup Seal	2
18*	934-000-002	Material Inlet Block (Al) For TS934	1
18*	934A-000-002	Material Inlet Block (Al) For TS934A	1
18*	941-000-001	Material Inlet Block (SS) For TS941	1
18*	941A-000-001	Material Inlet Block (SS) For TS941A	1
19	TSD912-15	Reducer, 3/8" NPT X 1/4" NPT	1
20	TSD918-3	Elbow, 1/4-18 NPT X 1/4-18 NPT	1
21	TSD931-15	1/4" NPT X Female Luer Lock Fitting	1
	TSD700-1	Oiler Cup, (NOT SHOWN)	1

5. SETUP INSTRUCTIONS

1. Connect the fluid reservoir feed tube (1) to the valve inlet port (2).
2. Connect the valve air line (3) to the valve controller or other pneumatic device that is used to control the valve.
3. Connect appropriate nozzle or dispensing tip (4) to the fluid outlet port.
4. Set the valve controller pressure at 70 psi (4.8bar).
5. Set the fluid reservoir pressure. Do not exceed 2,500 psi (172.4bar). (Strengthened hoses are required with pressures exceeding 100 psi (6.9bar).
6. Make sure all connections are correctly tightened.
7. Place container under the valve outlet and activate the valve until the fluid flows steady.

The amount of fluid that flows through the valve is determined by:

- Valve open time
- Fluid reservoir pressure
- Dispensing tip size

NOTE: An adjustable “suck-back” cap part number 934-003-000 is available.

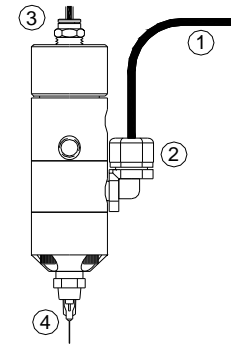

Figure 3.0

6. TYPICAL SYSTEM SETUP

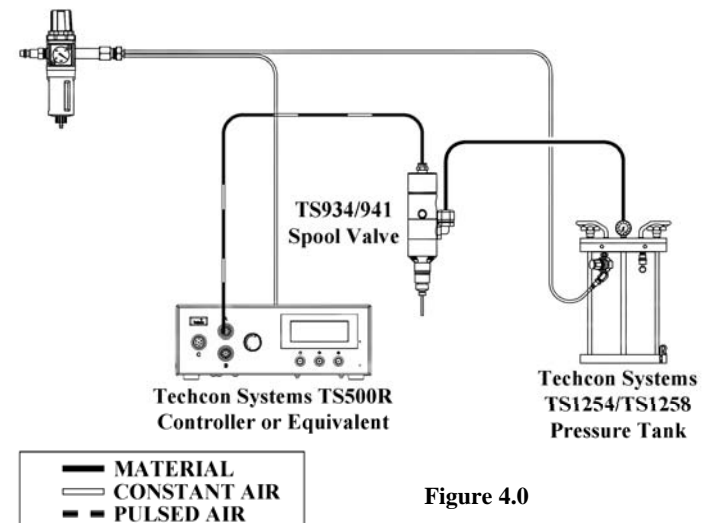

Figure 4.0

7. MAINTENANCE AND CLEANING:

Normally, purging the valve with an appropriate flushing material or solvent after use is sufficient for cleaning. However, some material may cause a buildup in the valve chamber, in this case periodic and thorough cleaning will be required.

CAUTION: Make sure fluid pressure is released before valve disassembly.

1. Release fluid pressure and disconnect fluid line.
2. Disconnect valve air line.
3. Remove end cap (1).
4. Pull out piston/spool assembly (4).
5. Remove the spring from air cylinder (2).
6. Remove socket head cap screws (10).
7. Separate material outlet block (9), material inlet block (6) and air cylinder (3). Clean these parts if necessary.
8. Replace o-rings (13) on the spool shaft, material outlet block (8) and air cylinder (12) if worn or damaged.
9. Remove lower seal (7) out of the outlet block and upper seal (5) out of the air cylinder using a small screw driver.
10. Clean seal seats and carefully install new seals. It is important that seals should be replaced in the same orientation to prevent leaks and accelerated wear.
11. Lubricate O-rings with "Parker-O-Lube" or equivalent. Only the spool shaft o-ring (13) should be lubricated with Bimba HT-99, or equivalent.
12. Assemble material outlet block (9), material inlet block (6) and air cylinder (3).
13. Thread socket head cap screws into assembled valve (10). Tighten uniformly to ensure correct valve alignment.
14. Insert the spring back into the air cylinder (2).
15. Insert piston/valve spool into valve body (4).
16. Install air fitting to end cap.
17. Install end cap to air cylinder (1). **(HAND TIGHTEN ONLY)**

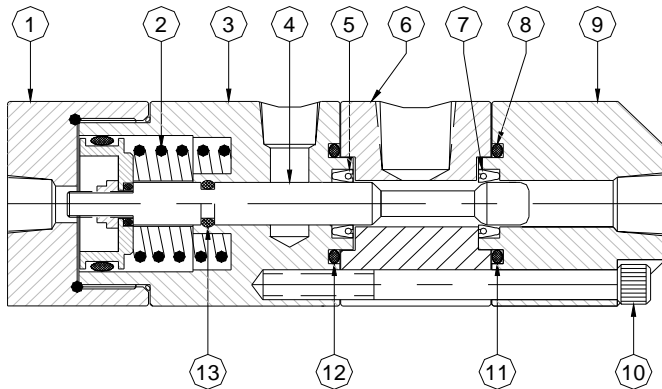

Figure 5.0

8. SPARE PARTS

Valve Rear Section

Recommended lubricant:

"Parker-O-Lube", or equivalent, except item 4 (TSD1400-008B) which requires Bimba HT-99, or equivalent.

All O-Rings & seals must be lubricated with the exception of TSD400-69, which must remain dry.

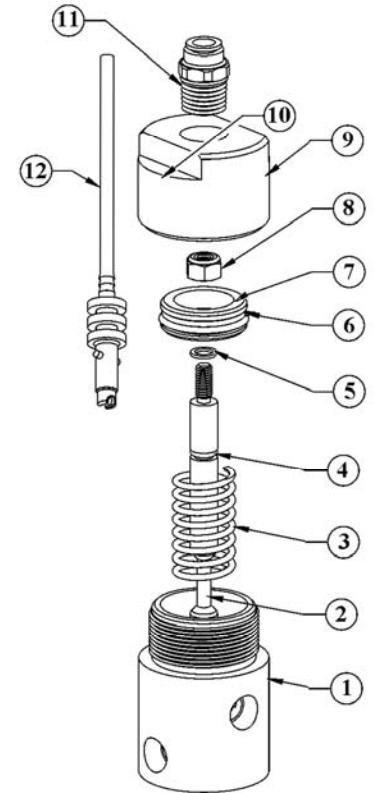

ITEM	PART NUMBER	DESCRIPTION	QTY
1*	934-000-001	Cylinder For TS934/TS941	1
1*	934A-000-001	Cylinder For TS934A/TS941A	1
2	934-000-005	Spool Shaft	1
3	934-000-006	Spring	1
4	TSD1400-008B	Spool Shaft O-Ring, Viton	1
5	TSD1145-1	Fiber Washer	1
6	TSD1399-2	Piston U-Cup Seal	1
7	934-000-004	Piston	1
8	TSD1116-4	Lock Nut	1
9	927-000-007	End Cap	1
10	TSD1400-025A	Cap O-Ring, Buna	1
11	TSD1002-26	Air Fitting, 1/4" Tube X 1/4" NPT	1
12	A0100268	Air Hose & Connector Assembly	1