



TS8100 Progressive Cavity (PC) Pump M-Series User Guide

CONTENTS

	Page number
1. Specifications.....	3
2. Dimensions and Typical Setup.....	4
3. Unpacking and Inspection.....	5
4. Description.....	6
5. Theory of Operation.....	6
6. Set-Up Instructions.....	7-11
6.1 Install the Stator	7
6.2 Mechanical Mounting	9
6.3 Connect the Pump to the Controller	10
6.4 Prime the Pump	10
6.5 Dispensing	11
7. Maintenance and Cleaning.....	12-14
7.1 Pump Purging	12
7.2 Thorough Cleaning	13-14
8. Spare Parts.....	15-16
9. Troubleshooting.....	17
10. Warranty.....	18

1. SPECIFICATIONS

Size (100/200/300)	261 mm L x 34 mm W (10" L x 1.3" W)
Size (400)	275 mm L x 34 mm W (11" L x 1.3" W)
Size (500)	301 mm L x 34 mm W (11.8" L x 1.3" W)
Weight (100-500)	640 g / 1.41 lb
Wetted Parts	Delrin (Acetal). PFE, stainless steel, UHMWPE
Fluid Viscosity	1-300K cps or m.Pa.s
Precision \pm , Absolute (1)	$\pm 1\%$
Self-sealing (2)	2 bar
Material Inlet Port	1/8" NPT
Material Outlet Port	Male Luer lock
Direct Mount Material Reservoir	3 to 55 cc

	TS8100-100M	TS8100-200M	TS8100-300M	TS8100-400M	TS8100-500M
Dispense Volume per Rotation (average)	0.012 ml	0.047 ml	0.070 ml	0.12 ml	0.31 ml
Flow Rate	0.15-1.04 ml/min.	0.47-4.46 ml/min.	0.74 – 6.7 ml/min.	1.2 – 12 ml/min	3.1 – 31 ml/min
Max. Flow Rate Recommended (3)	0.65 ml/min	3.38 ml/min	5.06 ml/min	8.0 ml/min	21 ml/min
Minimum Dispense Amount	0.001 ml	0.0045 ml	0.0068 ml	0.012 ml	0.031 ml

- (1) Volumetric dispensing as absolute deviation per complete revolution and depends on dispensing fluid.
- (2) 2 bar self-sealing is for fluid with viscosity of 1000 Cps or lower. The pump can handle up to 5.5 bar for 300K Cps viscosity fluid.
- (3) This is the maximum flow rate that does not shorten the stator work life

2. DIMENSIONS AND TYPICAL SETUP

LENGTH

100/200/300: [261 mm] 10"

400: [275 mm] 11"

500: [301 mm] 11.8"

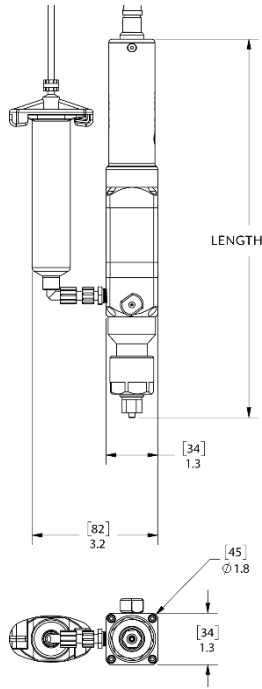

Figure 1.0

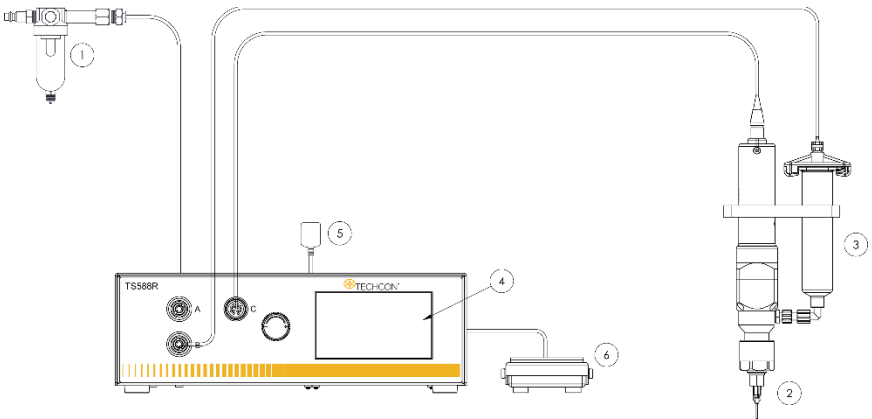

Figure 2.0

3. UNPACKING AND INSPECTION

Carefully unpack the pump and examine the items contained in the carton.

ITEM NO.	PART NUMBER	DESCRIPTION	QTY.
1	7509-9371	PC PUMP/TS8100-100M (without Stator)	1
	7509-9372	PC PUMP/TS8100-200M (without Stator)	1
	7509-9373	PC PUMP/TS8100-300M (without Stator)	1
	7509-9374	PC PUMP/TS8100-400M (without Stator)	1
	7509-9375	PC PUMP/TS8100-500M (without Stator)	1
2	8100-100-002	STATOR (TS8100-100M)	1
	8100-200-002	STATOR (TS8100-200M)	1
	8100-300-002	STATOR (TS8100-300M)	1
	8100-400-002	STATOR (TS8100-400M)	1
	8100-500-002	STATOR (TS8100-500M)	
3		CAP/NUT KIT: Includes the following items below	
	7509-0090	RETAINER NUT (100/200/300)	1
	7509-0680	RETAINER NUT (400)	1
	7509-0130	STATOR CAP BOTTOM (100/200/300)	1
	7509-0690	STATOR CAP BOTTOM (400)	1
	7090-0030	NEEDLE CAP	1
4	8100-CLEANKIT-M	CLEANING KIT	1
5		INSTRUCTION PACKET	1
6	7509-9390	CABLE ASSEMBLY, PC PUMP	1

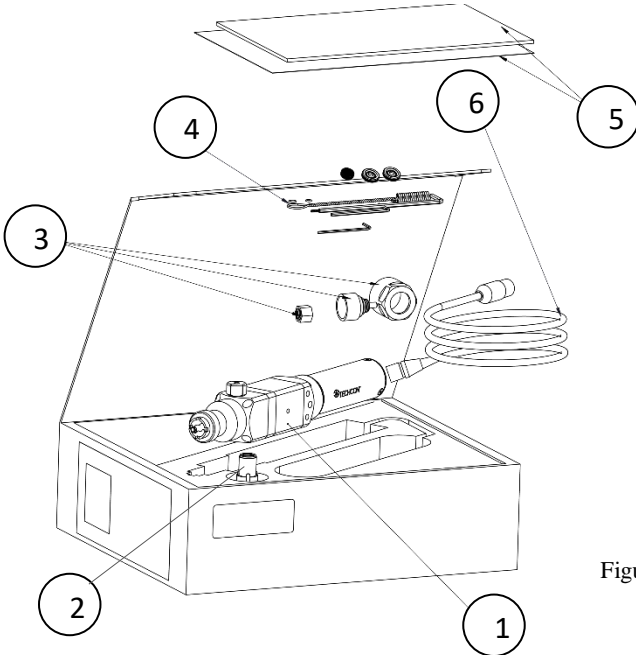

Figure 3.0

Inspect the unit for any damage which may have occurred in transit. If such damage has occurred, notify the carrier at once. Claims for damage must be made by the consignee to the carrier and should be reported to the manufacturer.

4. DESCRIPTION

The TS8100-M Series Positive Displacement Pump is a continuously volumetric dispense pump based on Progressive Cavity (PC) technology. The pump is designed to dispense a wide range of fluids, from low viscosity coatings to high viscosity greases. The many advantages of PC technology will simplify your dispense process and improve reliability and quality in the long run.

The TS8100-M Series PC Pump provides a consistent dispensing output due to a special design of sealed cavities in the fluid chamber which created a volumetric fluid flow. The two main components are the stator and rotor. The metal rotor seals tightly against the flexible rubber stator as it rotates, forming tightly sealed cavities which move toward the pump outlet, carrying the fluid. The pumped fluid does not change in shape or size during the dispense process. Accuracy and repeatability rate of $\pm 1\%$ is achievable.

5. THEORY OF OPERATION

The TS8100-M Series Positive Displacement Pump dispenses fluid with a positive displacement action using progressive cavity technology. Fluid is held in a feed reservoir (2) under a positive head of air pressure, up to 30 psi (2.07 bar), depending upon the viscosity of the fluid. This positive air pressure, supplied by the air line (1), forces the fluid out of the barrel (2) into the fluid feed path (3), then to the rotor/stator chamber assembly (4). Fluid flows from this point (4) to the dispense tip outlet and is controlled by the rotor rotation in the feed direction. The rotor is driven by the encoder DC motor (5). Applying a voltage signal to the motor (5) will rotate the rotor and the fluid will be forced out the dispense tip. The actual fluid deposited is dependent upon adhesion of the dispensed fluid to the substrate. Shearing of the fluid is achieved by reverse Z-motion (tip retraction). When the motor stops, the unit remains in position for a fraction of a second (dwell) to allow the last drop of fluid to flow out of the dispense tip. After the dwell period, the automation equipment moves the pump to the next position.

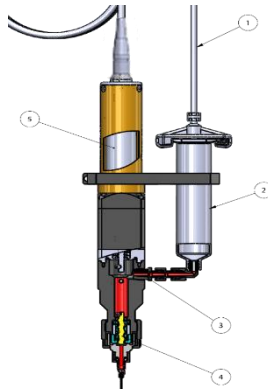

Figure 4.0

6. SET-UP INSTRUCTIONS

6.1 Install the Stator:

To prevent permanent set of the stator, the pump is shipped without the stator attached to the motor/rotor assembly. Follow instructions below to install the stator.

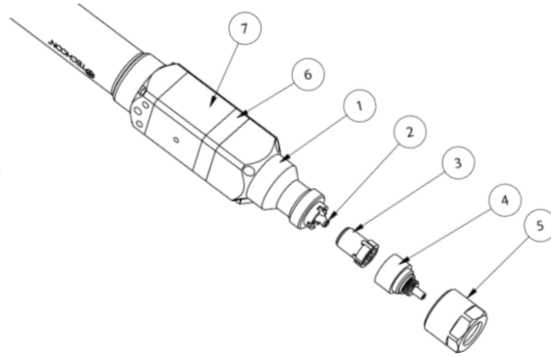

Figure 5.0

1. Wet the rotor (2) by applying the dispensing fluid (or any appropriate lube that is compatible with the dispensing fluid) to the exposed portion of the rotor surface.
2. Wet the stator (3) by squeezing a small amount of the dispensing fluid (or any appropriate lube that is compatible with the dispensing fluid) into the stator opening.
3. Screw the stator (3) onto the rotor (2) in the clockwise direction until the four (4) tabs of the stator align with the four (4) notches of the stator housing (see figure below).

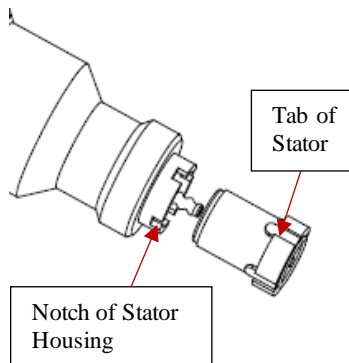

Figure 6.0

4. Apply some pressure on the stator by pushing it against the stator housing to make sure it fully seats into the notches. Check to make sure the rotor tip is flush with the stator.

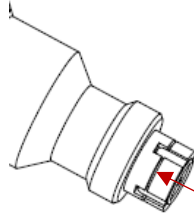

Figure 7.0

Push the stator against the stator housing

5. Place the stator cap (4) into the retaining cap (5).
6. Install the retaining cap (5) (with the stator cap in place) by screwing it onto the stator housing (1) in the clockwise direction.

6.2 Mechanical Mounting:

Normally, the TS8100-M Series PC Pump is used on an automation system such as a benchtop robot. It is very important that the pump is mounted on the Z-axis gantry, in a secure manner, that will not allow loosening during dispense operation. The Z-axis must move in a precise and repeatable motion for successful dispensing.

The provided mounting bracket must be attached to the Z-axis in a manner that will provide the valve travel perpendicular to the horizontal plane of the surface on which the fluid will be dispensed. The mounting should provide a means of accurately adjusting the distance between the dispense tip and the substrate surface, such as a touchdown sensing device or a fixed distance standoff.

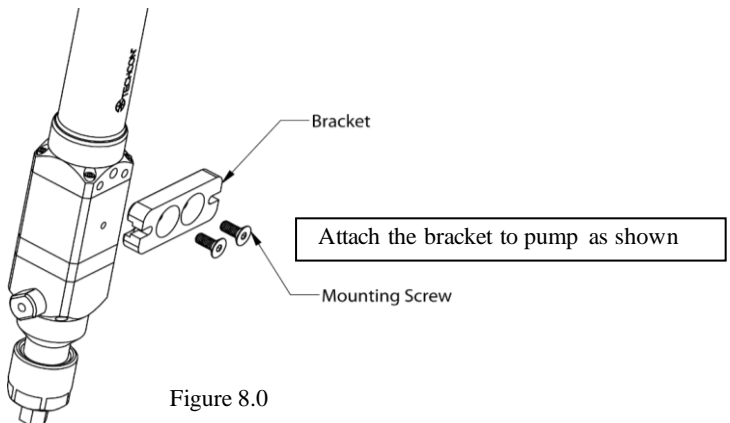

Figure 8.0

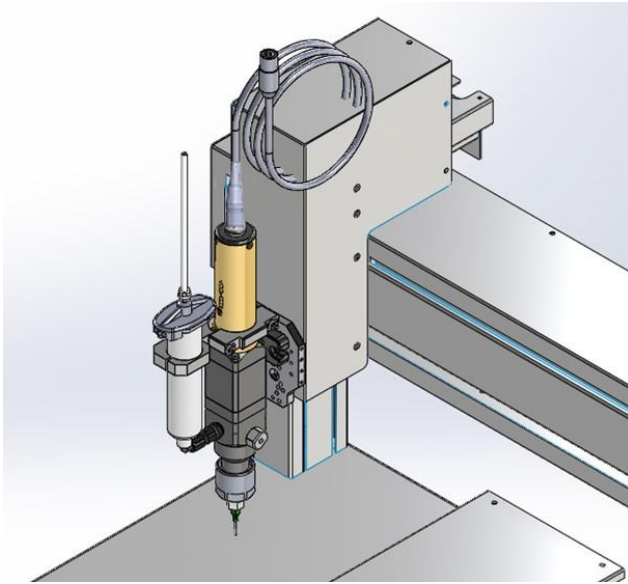

Figure 9.0

6.3 Connect the pump to the controller: refer to setup diaphragm below

The recommended controller for the TS8100-M Series PC Pump is the TS588R.

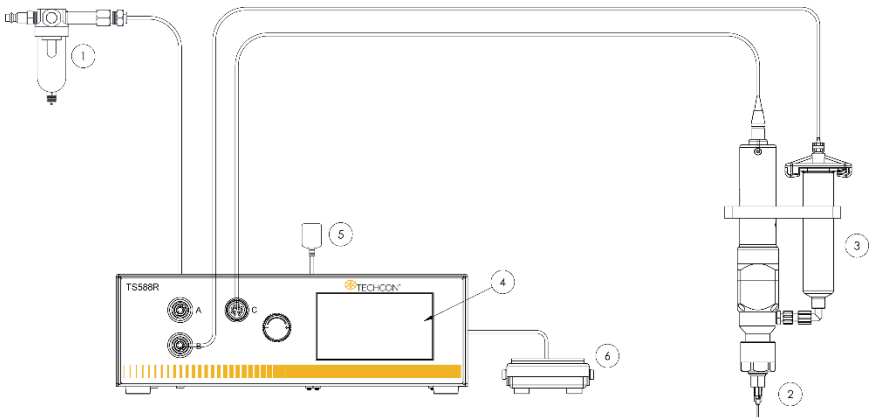

Figure 10.0

1. Connect the power adapter to the TS588R controller.
2. Connect the air hose to the TS588R controller.
3. Connect the motor cable to Port C. Note: Make sure the controller is turned off when connecting the motor cable to port C.
4. Connect syringe air hose to port B.
5. Set the air pressure to feed the material to the pump.
6. Note: For low viscosity material, the pressure setting should be 1 – 9 psi; for medium viscosity material, the pressure range setting should be 10-19 psi; for high viscosity material, the pressure range should be 20-80 psi.
7. Press the Power button to turn on the unit.

Please refer to the TS588R User Guide for complete operating instructions.

6.4 Prime the Pump

1. Enter the appropriate flow rate setting in the TS588R controller.
2. Select the “Purge” mode.
3. Press and hold the Foot Switch until a steady stream of material is flowing out the pump outlet without air bubbles.
4. Attach a dispense needle to the pump outlet.
5. Repeat step #2.



Figure 11.0

6. If air bubbles still appear in the material, open the vent hole by turning the vent screw counterclockwise to allow air bubbles to escape.

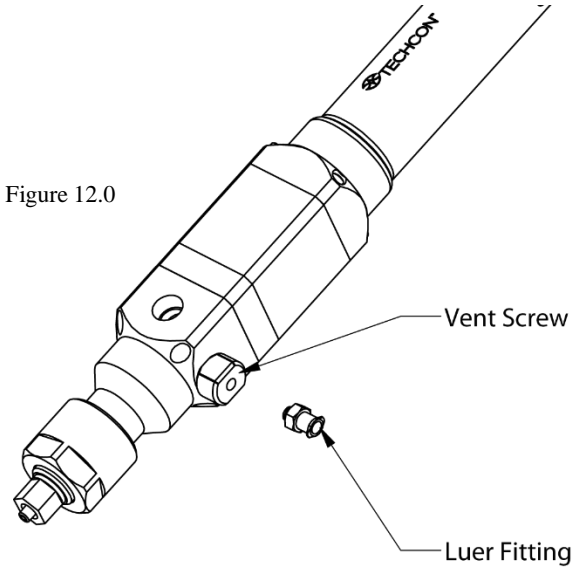

6.5 Dispensing:

1. Select the “Volume” Mode on the TS588R controller.
2. Enter the desired dispense volume.
3. Press and release the foot switch to activate the dispense cycle.

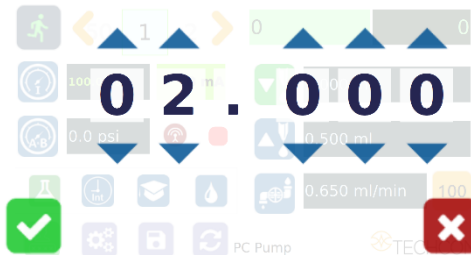

Figure 13.0

Note: If suck back is needed, touch the “Reverse” icon to setup reverse volume.

7. MAINTENANCE AND CLEANING:

7.1 Pump Purging:

Purging the pump with dispensing conditioner (P/N: 7305XCON) after each shift is recommended. The conditioner removes material residue from the material path and conditions the pump for future use.

1. Release material feed pressure.
2. Remove material from the pump.
3. Remove dispense tip.
4. Install a barrel of dispensing conditioner (P/N: 7305XCON) to the pump inlet and set air pressure at 10.0 psi.
5. Set the controller to “PURGE” mode.
6. Press the foot switch to let the pump run until the conditioner is the only material being dispensed at the pump outlet. If the conditioner is unable to force the dispense material out the pump outlet, then proceed to the “Thorough Cleaning” section.
7. Release the foot switch to stop pump.
8. Release conditioner feed pressure.

- 7.2 Thorough Cleaning:** refer to figure 14.0.
Recommended cleaning solvent: IPA or Acetone

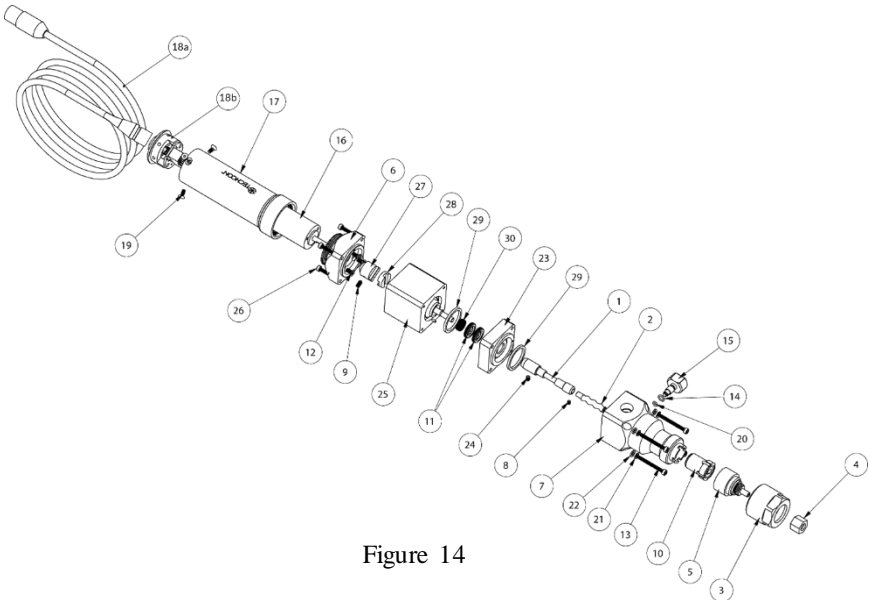
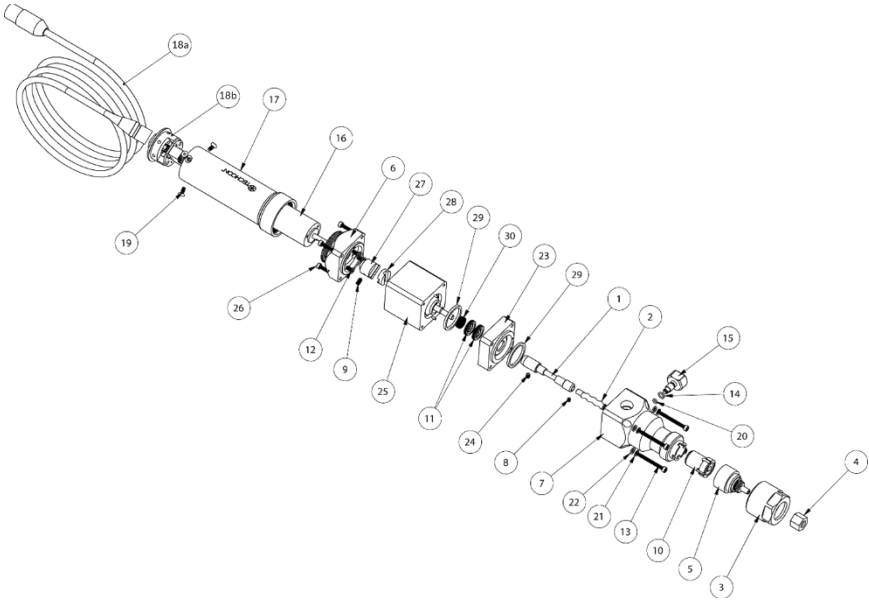

Figure 14

Thorough cleaning procedures should be done whenever the following occur:

- When the dispense material is changed to a different type.
 - When the dispense material has started to cure in the pump.
 - When the pump has been dispensing for one month.
 - When the dispense tip clogs frequently.
1. Perform pump purging process by follow steps 1-6 in Section 9.1 “Purging.”
 2. Remove the Material Inlet Fitting.
 3. Rotate the retaining cap (3) counterclockwise until it completely detaches from the stator housing (7).
 4. Pull the retaining cap (3), along with the stator cap (5) and the needle cap (4), straight out from stator housing (7).
 5. Remove the stator (2) by rotating it counterclockwise. If necessary, turn on the motor while rotating the stator.
 6. Use the 2 mm hex key to remove 4 mounting screws (13).
 7. Pull the stator housing (7), shaft seal block (23), shaft seals (11), O-ring, and bearing block assembly straight out.
 8. Submerge the stator (10) in a bath of cleaning solvent and use the cleaning brush (P/N: TSD2106-1, included in the cleaning kit) to clean the stator. Insert the brush in the center of the stator and rotate it until all residue is cleaned out.
 9. Use the same cleaning brush to clean the internal chamber of the stator cap.
 10. Use the soft cloth to wipe material residue off the rotor (2) surface.
 11. Continue to clean the rotor by dipping it in a solvent bath, then use the TSD2106-1 brush to remove any leftover residue.
 12. Use a soft cloth to wipe material residue off the cup seal (11).
 13. Inspect parts for wear or damage and replace if necessary.

8. SPARE PARTS:



Item	Part No.	Description	Qty
1	7509-9430	COUPLING, SHRINK TUBE COVERED	1
2	8100-100-001	REPLACEMENT ROTOR, SERIES 100, PC PUMP	1
	8100-200-001	REPLACEMENT ROTOR, SERIES 200, PC PUMP	1
	8100-300-001	REPLACEMENT ROTOR, SERIES 300, PC PUMP	1
	8100-400-001	REPLACEMENT ROTOR, SERIES 400, PC PUMP	1
	8100-500-001	REPLACEMENT ROTOR, SERIES 500, PC PUMP	1
3	7509-0090	RETAINER NUT, SERIES 100/200/300 PC PUMP	1
	7509-0680	RETAINER NUT, SERIES 400 PC PUMP	1
4	7090-0030	LOCKING CAP, TE NEEDLE, TS7000 IMP VALVE	1
5	7509-0130	STATOR CAP BOTTOM, SERIES 100/200/300 PC PUMP	1
	7509-0690	STATOR CAP BOTTOM, SERIES 400 PC PUMP	1
6	7509-0980	MOTOR MOUNT PLATE	1
7	7509-0920	STATOR HOUSING	1
8	2800-0836	SCREW, SET, M2.5 X 3MM LG, HEX SOCKET, SS	1
9	2800-0903	SCREW, SET, M3 X 0.5MM X 6MM LG, S.S	1

10	8100-100-002	REPLACEMENT STATOR, SERIES 100, PC PUMP	1
	8100-200-002	REPLACEMENT STATOR, SERIES 200, PC PUMP	1
	8100-300-002	REPLACEMENT STATOR, SERIES 300, PC PUMP	1
	8100-400-002	REPLACEMENT STATOR, SERIES 400, PC PUMP	1
	8100-500-002	REPLACEMENT STATOR, SERIES 500, PC PUMP	1
11	7509-0990	SEAL, SHAFT	2
12	2800-0901	SCREW, M3 X 6MM LG., FH, PHIL, MACH, SS	3
13	2800-1019	SCREW, M2.5 X 25MM LG, SHC, SS	4
14	3300-0617	O-RING, 6 OD X 4 ID X 1MM WIDTH, VITON	1
15	7509-0570	VENT SCREW KNOB, PC PUMP	1
16	2600-0185	MOTOR, 24 VDC, ENCODER, 83:1 GEAR REDUCTION	1
17	7509-0340	MOTOR COVER, SERIES 100 PC PUMP	1
18a	7509-9390	CABLE ASSEMBLY, PC PUMP	1
18b	7509-9400	MOTOR CONNECTOR ASSEMBLY, PC PUMP	1
19	2800-0900	SCREW, 4-20 X 1/4" THREAD FORMING, SS	1
20	3300-0616	O-RING, 4.5 OD X 2.5 ID X 1MM WIDTH, VITON	1
21	2800-0295	WASHER, M2.5, LOCK, MEDIUM, SS	4
22	2800-0917	WASHER, #4, 0.115 ID X 0.209 OD, 0.034 THK, SS	4
23	7509-0970	SHAFT SEAL, BLOCK	1
24	2800-0688	SET SCREW, M3 X 4MM LG, CUP POINT, S.S	1
25	7509-9340	FA, PRECISION PC PUMP WITH BEARING BLOCK ASSY	1
26	2800-0897	SCREW, M2.5 X 14mm LG. SHC, SS	4
27	7509-0950	COUPLING HALF TOP	1
28	7509-0960	COUPLING DISC	1
29	3300-0690	O-RING, SQUARE, 3/4" ID X 7/8" OD X 1/16 W, BUNA N	2
30	3300-0353	CUP SEAL, UHMW, SS. SPRING, TS7000	1

9. TROUBLE SHOOTING:

PROBLEM	POSSIBLE CAUSE	CORRECTION
No Fluid Flow	Dispense tip is clogged	Replace tip
	Motor does not receive signal	Make sure all connections are secured
	Motor running in reverse	Reverse motor cable connection
	Barrel of dispense fluid is empty	Replace with new fluid barrel
	Fluid feed pressure is too low	Increase feed pressure
Inconsistent Shot Size	Fluid dried or cured	Replace with new, fresh fluid
	Fluid pressure fluctuating	Make sure fluid pressure is constant
	Valve on-time is too short	Increase valve on-time
	Excessive motor reverse time	Reduce reverse time or turn off completely
	Air trapped in fluid	Purge valve properly
Skipped Dots	Intermittent motor signal	Check and replace motor
	Air trapped in fluid	De-air fluid
Fluids Drools After Valve is Turned Off	Air trapped in fluid chamber	Purge valve properly
	Air trapped in fluid reservoir	Remove air from reservoir

10. LIMITED WARRANTY:

Manufacturer warrants this product to the original purchaser for a period of one (1) year from date of purchase to be free from defects in materials and workmanship, but not against damages by misuse, negligence, accident, faulty installations, and instructions. The Manufacturer will repair or replace (at factory's option), free of charge, any component of the equipment thus found to be defective, on return of the component, "PREPAID," to the factory during the warranty period. In no event shall any liability or obligation of the Manufacturer arising from this warranty exceed the purchase price of the equipment. This warranty is only valid if the defective product is returned as a complete assembly without physical damage. The Manufacturer's liability, as stated herein, cannot be altered, or enlarged, except by a written statement signed by an officer of the company. In no event shall the Manufacturer be liable for consequential or incidental damages. A return authorization is required from Techcon prior to shipping a defective unit to the factory.

The Manufacturer reserves the right to make engineering product modifications without notice.

All returns must be issued with a Returns Authorization number, prior to return. Send warranty returns to:

Americas

OK International
10800 Valley View Street
Cypress, CA 90630

Europe

OK International
Eagle Close
Chandler's Ford Ind Est
Eastleigh
Hampshire
SO53 4NF
United Kingdom

Asia

OK International
4th floor East, Electronic Building,
Yanxiang Industrial Zone, High Tech Road,
Guangming New District, Shenzhen P.R.C

Delrin®, Viton® and Teflon® are registered trademarks of E.I. DuPont.

7000-7140_B (8-17-2023)

For Sales and Support:

Techcon Corporate Headquarters
10800 Valley View Street
Cypress, California, 90630, USA
Tel: 1-714-799-9910 | Fax: 1-714-828-2001
E-mail: oemorders@okinternational.com

Visit our website to contact the
Techcon office nearest you.

techcon.com/contact-us

