

10. SPARE PARTS AND ACCESSORIES

10.1 SPARE PARTS: The only spare parts available are: Fluid inlet fitting, O-ring and clean out screw. These items are included in the Valve cleaning kit part number: 5000-013-000

10.2 ACCESSORIES

PART NUMBER	DESCRIPTION
5000-000-080	Torque wrench for metal valve
5000-000-082	Torque wrench for plastic valve
7105XCON	Dispensing conditioner, 10-CC, 700 series syringe
7305XCON	Dispensing conditioner, 30-cc, 700 series syringe

11. WARRANTY

Manufacturer warrants this product to the original purchaser for a period of one (1) year from date of purchase to be free from defects in material and workmanship, but not against damages by misuse, negligence, accident, faulty installations and instructions. Manufacturer will repair or replace (at factory's option), free of charge, any component of the equipment thus found to be defective, on return of the component, "PREPAID" to the factory during the warranty period. In no event shall any liability or obligation of the Manufacturer arising from this warranty exceed the purchase price of the equipment. This warranty is only valid if the defective product is returned as a complete assembly without physical damage. The Manufacturer's liability, as stated herein, cannot be altered or enlarged except by a written statement signed by an officer of the company. In no event shall the Manufacturer be liable for consequential or incidental damages. A return authorization is required from Techcon Systems prior to shipping a defective unit to the factory.

Manufacturer reserves the right to make engineering product modifications without notice.

Send warranty returns to:

OK International
Garden Grove Division
12151 Monarch Street
Garden Grove, Ca 92841

Techcon Systems TS5000 Series Rotary Valve

User Guide



CONTENTS

	Page number
1. Specifications	3
2. Unpacking and inspection.....	4
3. Description.....	4
4. Theory of operation.....	5
5. Setup instructions	
5.1 Mechanical Mounting.....	6
5.2 Electrical Connection.....	6
5.3 Air Connection	7
6. Typical system setup	7
7. Dispensing application	8
8. Troubleshooting	10
9. Maintenance and cleaning	
9.1 Valve purging	11
9.2 Thorough cleaning	12
9.3 Valve reassembly	14
9.4 Priming the valve	15
10. Spare parts and accessories	16
11. Warranty	16

9.4 Priming the valve:

The valve is shipped with conditioner filled inside valve chamber to ensure the valve is not run “dry” during initial start-up.

CAUTION: Running the valve dry (without dispense material) may cause damage to the feed screw and chamber.

1. Attach a barrel of dispensing conditioner (Part number 7305XCON) to the valve inlet.
2. Apply 8 psi pressure on the barrel and let the pressure push the conditioner through the valve for 2 minutes. Do not apply more than 10 psi on the conditioner when priming as this may cause compressed air pockets in the valve chamber.
3. Turn on the motor and let it run until a steady stream of fluid is being dispensed.
4. Turn off motor.
5. Install appropriate dispense tip to the valve outlet. Do not over tighten the dispense tip.

Note: Techcon makes available a torque wrench that is designed to fit Techcon supplied dispense tip. (Part number: 5000-000-080 for metal valves and 5000-000-082 for Delrin valves)

17. Visually inspect the valve body to any foreign material and repeat cleaning process if necessary.
18. Insert a 0.1255" pin gauge into the valve body from the motor side. If the pin moves smoothly and easily through the valve body, there are no detrimental deposits in the valve. If the pin stop or snags, gently push the pin through the hole to remove any deposits. If the pin still does not want to move, please return the valve for repair.
19. Insert a 0.1262" pin gauge to into valve body from the motor side. If the pin goes through the hole, please return the valve for repair.

9.3 Valve re-assembly

1. Reinstall the female luer lock fitting (10) into the valve body. Make sure to apply some thread sealant on the fitting, such as Loctite 222.
2. Place the O-ring (8) on the clean out screw (9) and reinstall the clean out screw assembly into the 45° feed shaft.
3. Lubricate the O-ring (3) with appropriate O-ring grease such as Parker O-Lube.
4. Install O-ring (3) to the feed screw.
5. Gently slide the motor/feed screw assembly into the valve body

CAUTION: The fit between the feed screw and the chamber is very precise. Extreme care must be taken during this operation.

6. Reinstall the two socket head screws (6) into the valve body. Alternately tighten the screws a little at a time until both are secure. Do not over tighten as this may distort the mounting plate and misalign the feed screw.

1. SPECIFICATIONS

Motor options:	2.7-Watt, 6-Watt, 6-Watt with digital encoder
Speed options:	125, 250, 400 RPM
Feed screw size options:	8-pitch standard 8-pitch high output 16-pitch standard 16-pitch shallow
Feed screw material options:	Stainless steel Delrin Carbide
Feed screw chamber options:	Stainless steel Delrin
Valve body options:	Anodized aluminum Delrin
O-ring options:	Viton, EPR

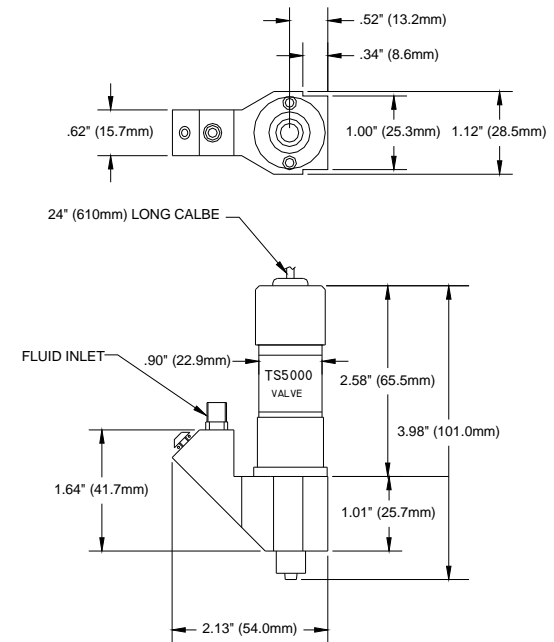

Figure 1.0 Valve with 2.7 Watt Motor

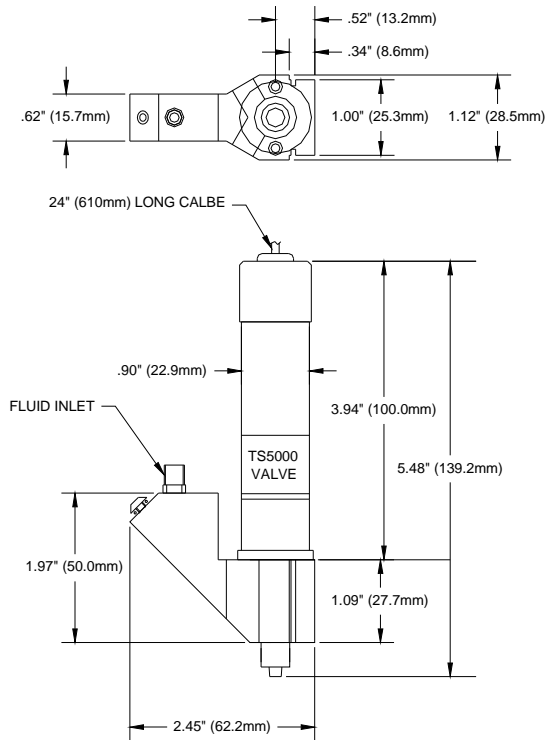

Figure 2.0 Valve with 6.0-Watt Motor

2. UNPACKING AND INSPECTION

Carefully unpack the valve and examine the items contained in the carton. These will include:

- Valve Assembly
- Valve bracket
- Sample syringe kit
- Sample Needle Kit
- Cleaning kit
- User guide

3. DESCRIPTION

The TS5000 is a self contained fluid dispensing valve capable of depositing shots down to 0.008" (0.200mm) in diameter at rates of 5 shots per second. Fluid can also be accurately dispensed in continuous beads in widths from 0.008" (0.200mm) at rates up to 4" per second. In both cases, dot or bead, accurate and repeatable dispensing can be accomplished in production by following the instructions in this manual.

assembly. (Make sure not to tilt the motor during this process.) Turn the motor off. If the motor/feed screw assembly still cannot easily be removed, return the valve for repair.

8. Disconnect the motor cable (1) from the controller.
9. The entire feed screw (4) can now be cleaned with a solvent. Use the brush included the cleaning for this process. Rho-Chem 7642 or a similar solvent can be used.

CAUTION:

- ***Do not drop, or exert any forces on the feed screw. This will cause permanent deflection in the alignment of the feed screw to the motor shaft***
- ***Do not remove the feed screw from the motor shaft during cleaning. Doing so will cause misalignment between feed screw and motor shaft***
- ***Do not submerge motor in solvent***

10. Visually inspect the feed screw as closely as possible and make sure the feed screw is free of all foreign material. Repeat cleaning operation if necessary
11. Remove the clean out screw (9) and O-ring (8) from valve body (5)

CAUTION: Do not remove the male luer lock fitting and locking hub (12) from the valve body (5). This is a precisely aligned part. Removal of this part will damage the valve permanently.

12. Using the brush provided, clean the feed screw chamber with solvent.
13. Using a micrometer to measure the major diameter of the feed screw threads. If the diameter is measure less than 0.1240", return the valve for feed screw replacement.
14. Replace the O-ring (3) on the feed screw (Part number TSD1400-010B)
15. Using the brush provided, clean the valve body with solvent.
16. Use dry air pressure to blow out passageways.

Note: Solvent can be used for purging instead of conditioner. If a solvent is used, remember to reduce air pressure. Also check the chemical compatibility chart to determine if solvent used will not affect the Viton O-ring on the feed screw.

9.2 Thorough Cleaning:

A more thorough cleaning procedure should be done whenever the following occur:

- Dispense fluid is changed to different type.
- Dispense fluid started to cure in the valve
- Valve has been dispensing for one month.
- Dispense tip clogged frequently.

Tool required: Open-end wrench, 3/32 hex wrench (included in valve cleaning kit, part number: 5000-000-013)

1. Follow steps 1-7 in “Valve Purging” section.
2. Remove barrel of conditioner (11) from the valve assembly.
3. Disconnect the motor cable (1) from the controller.
4. Using a 3/32 hex wrench to unscrew the two socket head screws (6) from the valve assembly.
5. Grasp the motor assembly (2) as close to the valve body (5) as possible. (Pulling on the motor assembly near the cable and may result in separation on the motor from the gear head.) Gently pull straight up on the motor assembly. The motor/feed screw assembly should pull out of the valve body. Do not pry on the motor if the motor/feed screw assembly does not withdraw easily. If the motor/feed screw assembly has been removed from the valve, go to step 10, otherwise continue to step 7.
6. Reattach control cable (1) to the controller, taking care to properly attach with correct polarity. (Feed screw should rotate counterclockwise when viewed from the dispense tip.)
7. Grasp the motor near the valve body to keep the motor from rotating. With the motor running, pull straight up on the motor/feed screw

The amount of fluid dispensed will be determined by the following parameter:

- DV Voltage input
- Motor assembly selections
- Feed screw pitch

4. THEORY OF OPERATION

The TS5000 Rotary Microvalve dispenses fluid with a positive displacement action using a rotary feed screw principle. Fluid is held in a feed reservoir (1) under a positive head of air, between 1 to 20 psi, depending upon the viscosity of the fluid. This positive air pressure, supplied by the air line (7), forces the fluid out of the barrel (1) into the vertical feed shaft of the valve body (2), and then through the angled feed shaft (3), to the feed screw chamber (4). Fluid flows from this point (4) to the dispense point (5) is controlled by the feed screw rotation in the feed direction. The feed screw is driven by the DC motor (6). Applying a DC voltage signal to the DC motor (6), will rotate the feed screw and the fluid will be forced out the dispense tip. The actual fluid deposited is dependent upon adhesion of the dispensed fluid to the substrate. Shearing of the fluid is achieved by reverse Z-motion (tip retraction). When the motor stops, the unit remains in position for a fraction of a second (dwell) to allow the last drop of fluid to flow out of the dispense tip. After the dwell period, the automation equipment moves the TS5000 valve to the next position.

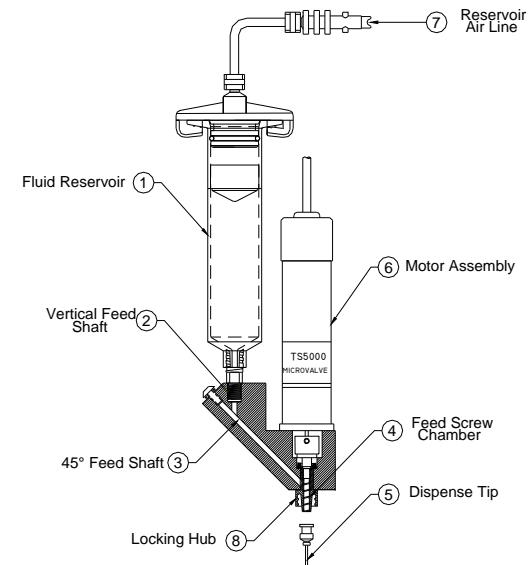

Figure 3.0

5. SETUP INSTRUCTIONS

5.1 Mechanical Mounting:

Normally, the TS5000 valve is used on an automated XYZ table with full motion control in the three planes. It is very important that the valve be mounted on the Z-axis gantry in a secure manner that will not allow loosening during dispense operation. The Z-axis must move in a precise and repeatable motion for successful dispensing.

The provided mounting bracket, or customer supplied bracket, must be attached to the Z-axis in a manner that will provide the valve perpendicular travel to the horizontal plane of the surface on which the fluid will be dispensed. The mounting should provide a means of accurately adjusting the gap between the dispense tip and the substrate surface such as a touchdown sensing device or a fixed distance standoff.

5.2 Electrical Connection:

The TS5000 valve requires an electrical connection of two wires for the DC motor. The motor lead wires are 24" long. The black lead wire should be connected to the negative or neutral lead from the motor control voltage source. To verify the connection, check the rotation direction of the feed screw. When correctly connected, a positive voltage signal will drive the feed screw in a counter clockwise direction when view from the dispense tip end.

The recommended controller for the TS5000 valve is the TS500R. If another controller is used made sure the control voltage signal is precisely control. The signal should be from a regulated power supply and should be shunted to positive motor stop. Below is a diagram of a simple braking circuit:

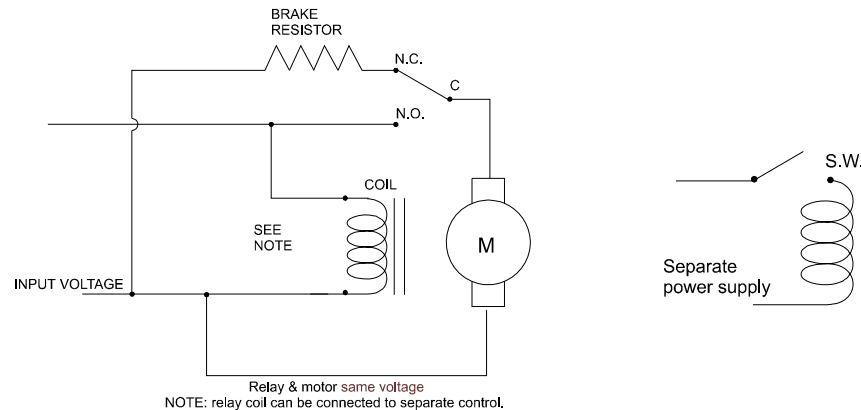

Figure 4.0

9. MAINTENANCE AND CLEANING:

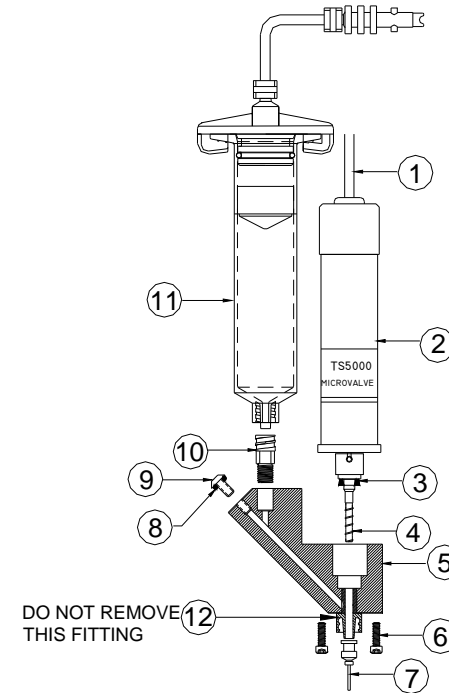

Figure 6.0

9.1 Valve Purging:

Refer to figure 6.0

4. Release fluid pressure.
5. Remove barrel of fluid (11) from the valve.
6. Remove dispense tip (7).
7. Install a barrel of dispensing conditioner (Part number 7305XCON) to the valve inlet (10).
8. Set air pressure at 8.0 Psi.
9. Turn on valve and let it run until the conditioner is the only material being dispensed at the valve outlet. If the conditioner is unable to force the dispense fluid out the valve then proceed to the "Thorough Cleaning" section.
10. Turn off valve and release air pressure.

8. TROUBLESHOOTING

PROBLEM	POSSIBLE CAUSE	CORRECTION
No Fluid Flow	Dispense tip is plugged	Replace tip
	Motor does not receive signal	Make sure all connections are secured
	Motor running in reverse	Reverse motor cable connection.
	Barrel of dispense fluid is emptied	Replace with new fluid barrel.
	Fluid feed pressure is too low	Increase feed pressure.
	Valve damaged	Return valve to factory for refurbishment
Inconsistent Fluid Flow	Fluid pressure fluctuating	Make sure fluid pressure is constant
	Valve on time is too short	Increased valve on time.
	Excessive motor reverse time	Reduce reverse time or turn off completely.
	Air trapped in fluid housing	Purge valve properly
Fluid drools after the valve turned off	Air trapped in fluid housing	Purge valve properly
	Air trapped in fluid reservoir	Remove air from reservoir
	Excessive fluid feed pressure	Reduce pressure or turn off pressure when the valve is idled.
Dispense tip clogged	Tip contacting substrate	Increase dispense height
	Tip bent or damaged	Replace tip
	Particles size in fluid too big	Replace with bigger tip

5.3 Air connection:

Filtered air supply must be precisely regulated and should be set between 1-20 psi. The air supply is not used as the main dispensing force. It is only required to move the fluid to the feed screw chamber.

The valve is supplied with sample of 10 and 30-CC air power syringe assembly. The syringe of fluid can be mounted directly onto the valve inlet fitting. Fluid can also be supplied from a remotely located container, such as cartridge systems.

6. TYPICAL SYSTEM SETUP

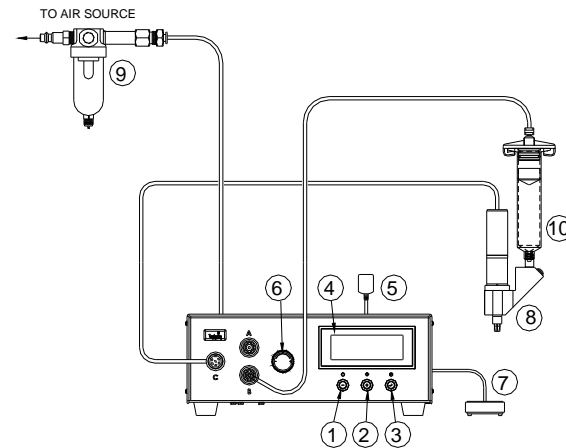

Figure 5.0

Items	Description	Items	Description
1	Power Button	6	Air pressure regulator knob
2	Mode Button	7	Foot Switch
3	Set Button	8	TS5000 Rotary Pump
4	LCD Display	9	Air Filter
5	Power Adapter	10	Material reservoir

7. DISPENSING APPLICATIONS

The following details of dispensing applications are extremely important. The dispense rate and repeatability rate of the valve can be affected by these parameters:

A. DC Motor Voltage Level:

Voltage controls motor speed (RPM). High voltage produces high motor speed and low voltage reduces motor speed.

B. Motor shaft Speed:

Motor gear ratio configuration determines final shaft speed. High RPM = High Output. Low RPM = Low Output.

C. Feed screw pitch:

Rate of fluid dispensed is determined by the pitch of the feed screw. A high pitch number will produce a low dispense rate and a low pitch number will produce a higher dispense rate.

D. Dispense tip:

The size of the dot diameter or bead width is determined by the dispense tip. A low gauge number (larger I.D.) will dispense a large diameter dot or a wide bead. A high gauge number (smaller I.D.) will dispense a smaller diameter dot or a narrower bead. Dispense tip sizes smaller than 25-gauge and longer than 1/2" are not recommended to use with solder paste. A normal rule of thumb to choose the dispense tip size is that the dot size equal 1.5 times the internal diameter of the dispense tip.

E. Fluid feed pressure:

The fluid feed pressure does affect the amount of fluid dispensed through the valve. Optimum feed pressure is dependent upon viscosity of fluid dispensed. Only in unusual circumstances should the feed pressure exceed 20 psi.

F. Dispense Fluid:

The viscosity of the dispense fluid along with the particulate additives to the dispense fluid will also determine the dispense rate. Ability to dispense may be directly related to the fluid formulation.

G. Dispense cut off:

The best method of stopping fluid flow at the end of the cycle is to short the motor (grounding the DC voltage signal through a current limiting resistor). This method provides a complete rotational brake of the motor at the shut off point. Another method of stopping fluid flow is to reverse the motor rotation by reversing the DC voltage signal. This can be described as suck-back action. In both cases, a no-drip dispensing action can be achieved. Turn off the fluid feed pressure when the valve is not dispensing will prevent dripping and oozing.

H. Dispense tip height:

The distance between the dispense tip and substrate surface is extremely important. To obtain accurate dot size, the dispense tip height should remain constant for each dot/bead. If the dispense tip height fluctuates during dispense process, the dot/bead size will vary. If the dispense tip touches the dispense surface, clogging will occur.

I. Fluid (Material) condition:

The physical condition of the dispense fluid is very important to successful dispensing. There are a number of conditions that can prevent continuous and consistent dispensing such as:

1. Freshness: Old fluid (most fluid have a recommended shelf life) leads to erratic dispensing and frequent clogging, especially with solder paste. Make sure to check the fluid shelf life before starting the dispense process.
2. Separation: Fluid with high content of solid particles, such as solder paste, tends to separate at high pressure. If the dispense fluid started to separate, please replace it with new fresh fluid.
3. Particles sizing: Do not attempt to dispense solder paste with particle sizes bigger than 75 microns (-200+325 mesh size).